

An Introduction to Fiber Optics and Broadcasting

By Geoff Snell

In previous tutorials in this series, we have examined the serial digital video interface, ancillary data, and error detection and handling (EDH), and have looked into asynchronous transfer mode (ATM). This article will deal with the principal transmission medium for ATM — fiber optics.

Optical communication has been with us longer than many people might think. In the 1870s, John Tyndall demonstrated that light used internal reflections to follow a specific path. Later on, in the 1880s, Alexander Graham Bell developed what he called the photophone. This device was constructed to allow specially placed mirrors to reflect sunlight onto a diaphragm attached to the mouthpiece of the photophone. The other end consisted of a selenium resistor connected to a battery which, in turn, was connected to a telephone receiver. Therefore, speaking into the photophone caused variations in light intensity, and subsequently, variations in current through the resistor, allowing the pulses to be converted back into speech.

“I have heard a ray of sun laugh and cough and sing.”— Alexander Graham Bell, 1880.

Although the technology to support Bell’s photophone was unavailable, Bell believed that the photophone was

superior to the telephone, as it did not require wires to connect the transmitter and receiver.

It was not until the latter half of the 20th century that fiber optics really came into being. In the 1950s the fibroscope was developed, which was an image-transmitting device used mainly to inspect welds. The fibroscope utilized the first practical glass-coated glass fiber.

The invention of lasers was the next step in the fiber-optic process. Lasing was first observed in semiconductors in the early 1960s; this was the beginning of the use of lasers for fiber optics. The advantages of lasers as a communications mechanism was readily apparent given the available bandwidth; however, lasers were unsuited to open-air transmission due to environmental considerations such as weather. It was at this point, in the late 1960s, that the idea of using optical fiber as a transmission medium was discussed, providing that the attenuation rates could be properly controlled. In the 1970s glass fabrication techniques were refined enough to meet the requirements. From this point on, fiber optics were on their way to becoming a viable means of communications.

Basic Transmission Comparisons

There are basically three types of transmission media available: copper wire, free space, and waveguides. Copper wire, such as coaxial cable, is widely used and the principles are well understood. A signal is typically transmitted down the wire in either analog or digital form to a receiver located (although not necessarily) at the end of the wire. Free-space transmission is also widely used. This is the way radio, television, and other over-the-air signals are carried. The last transmission medium, waveguides, described fiber-optic transmission. Essentially, a waveguide such as an optical fiber, confines the electromagnetic radiation — light.

Benefits of Fiber

Fiber-optic transmission offers the best components of both coaxial and free-space transmission. It has the ability to carry a signal from point A to point B without using the limited electromagnetic spectrum. However, it does not suffer from very limited bandwidth and data rate the way coaxial cable does.

Fiber-optic communication has many benefits over coaxial, as follows:

- Immunity from electromagnetic noise
- Longer distance capability
- Light weight
- High signal quality

This is the ninth in a series of tutorial articles from Leitch Technology International, Inc. Geoff Snell is with Leitch Technology Centre, Ottawa, Ont., Canada 2E 7S4. Copyright © 1996 by the Society of Motion Picture and Television Engineers, Inc.

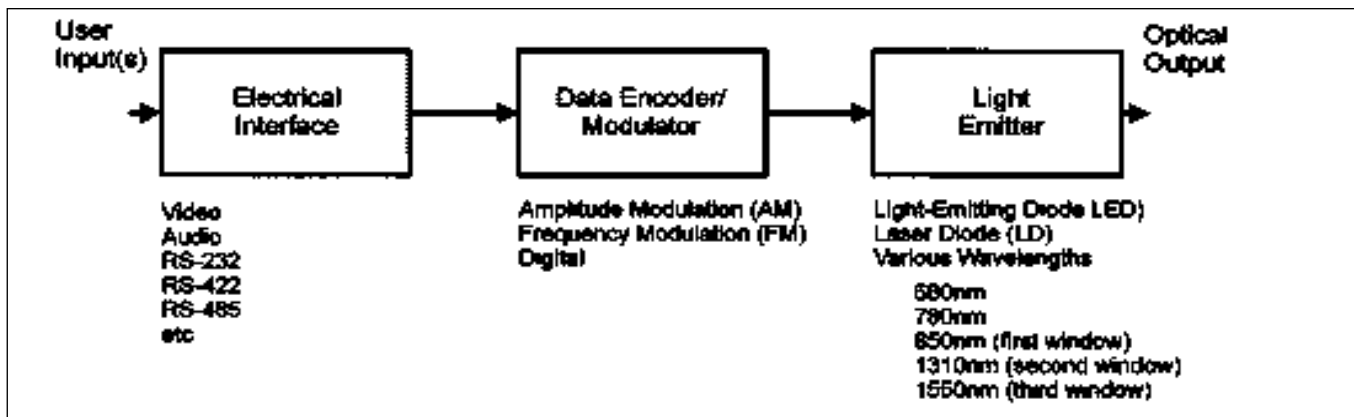

Figure 1. Fiber-optic transmitter (courtesy of Force, Inc.).

- High bandwidth, greater information capacity
- Lower cost
- Easy upgrade

Fiber-Optic Components

Fiber-optic transmission consists of the same basic components as any other form of transmission. There is an input signal which is converted to light at the transmitter, the transmission path which is fiber-optic cable in this case and a receiver that converts the light back into a representation of the original input signal.

Transmitter

The transmitter (Fig. 1) is an electrical interface that is designed for a specific purpose. This may be to accept analog video or audio, digital video or audio, or data in some form. In any case, the input is buffered in some fashion and then encoded and modulated as requirements dictate. At this point the signal is ready for the final process — conversion to light. This is accomplished by either a light-emitting diode (LED) or a laser diode (LD). There are advantages and disadvantages associated with either device used for transmission. The selection will depend upon the specific requirements in each case. Figure 2 lists some of the points of comparison between the LED and LD.

Fiber-Optic Cable

The fiber-optic cable itself is probably the most critical aspect of the whole transmission path. Like coaxial cable, there are various types and grades of fiber-optic cable available. The selection of a particular fiber-optic cable will depend on the specific requirements in question.

Fiber-optic operation is based upon the principle of total internal reflection. Basically this means that all of the light is reflected within the fiber-optic cable itself. You can get a better idea of this concept by imagining looking into water. At a shallow angle you only see a reflection from the surface. At a steeper angle, you can begin to see into the water. The angle at which light hits is called the angle of incidence. As the angle of incidence increases to the point where an angle of refraction of 90° is achieved, this is known as the critical angle. If the angle of incidence is increased beyond this point, we achieve total internal reflection.

Fiber-optic cable consists of extremely thin strands of ultrapure glass. The most important factor is purity, as this is what permits practical transmission lengths to be achieved. The greater the purity of the glass, the lower the attenuation.

The strands of ultrapure glass are known as the core, which will have a

dimension ranging from 9 to 100 μm, depending upon the type. Surrounding the core is a region called the cladding, which is responsible for reflecting the light back into the core. The cladding will have a diameter of 125 or 140 μm, depending upon the type. The key design feature here is that the refractive index of the core is higher than that of the cladding (Fig. 3 provides a rough size comparison). The outer region of the fiber is a coating or buffer designed to provide protection and strength for the fragile interior. This outer coating might be made from Kevlar, for example.

There are two basic types of fiber-optic cable: multimode (MM) and single-mode (SM). Multimode fiber was the first commercially available fiber-optic cable. Its core is much larger than that of single-mode, allowing hundreds of light rays (or modes) to move through the fiber simultaneously. Single-mode, as its name suggests, allows a single ray. While this may suggest that MM would be superior, this is not the case. SM is better at retaining the fidelity of each light pulse over longer distances, therefore allowing more information to be transmitted. However, as SM has a smaller core, it is more difficult to couple light into it (Fig. 3).

Receiver

The light source, either an LED or LD, is an electro-optical device used to convert electrical information into light information (Fig. 4). The receiver initial stage is a detector, which is an opto-electrical device used to convert the light information back into electrical information. The most common detector is a photodiode, which produces current in response to incident light.

From this point on, the reverse process that took place in the transmitter section will likely, but not always, occur. The signal will be demodulated, decoded, and then passed to an output buffer stage.

Fiber-Optic Losses

Is fiber-optic transmission perfect? No. As with any transmission path, there are associated losses, and fiber-optic transmission is no exception. Fiber-optic losses consist of scatter-

Parameter	LED	Laser
Output Power	Linearly proportional to drive current	Proportional to the current above the threshold
Current	Drive current: 50 - 100mA	Threshold current: 5 to 40mA
Coupled Power	Moderate	High
Bandwidth	Moderate	High
Wavelengths Available	0.66 to 1.55μm	0.78 to 1.55μm
Cost	\$5 to \$300	\$100 to \$10,000
Emission Spectrum	40nm to 190nm FWHM	1nm to 10nm FWHM
On / Off Efficiency	Good / Poor	Good / Good
Safety Requirements	None	Yes *

* Care must be taken to ensure a laser emitter is never disconnected when active or all of energy is sent back to be dissipated in the cavity (return loss meltdown)! Also, never look into a laser emitter or severe eye damage may result!

Figure 2. Source comparison of LED vs. laser (courtesy of Force, Inc.).

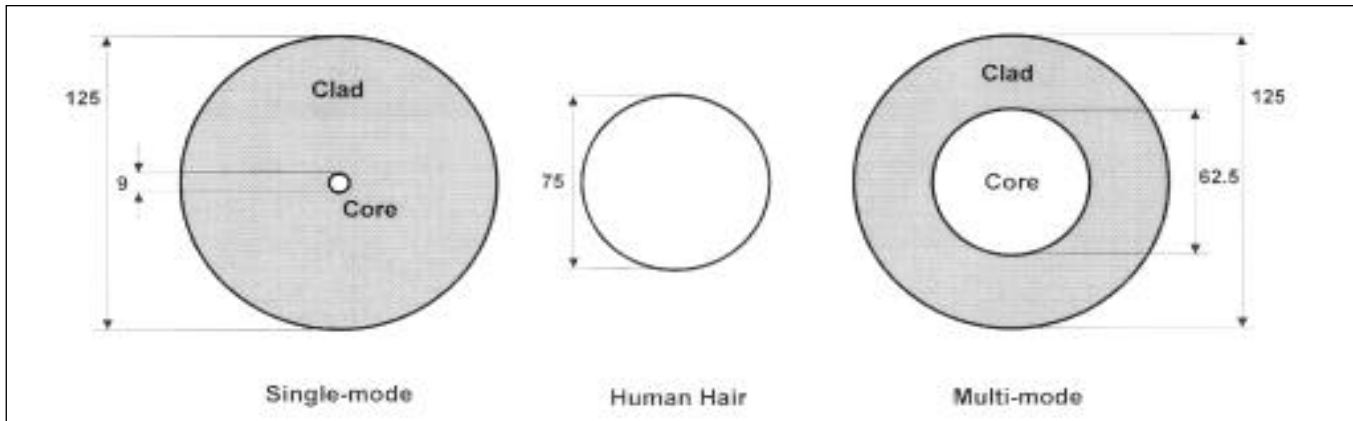

Figure 3. Relative sizes for optical fiber.

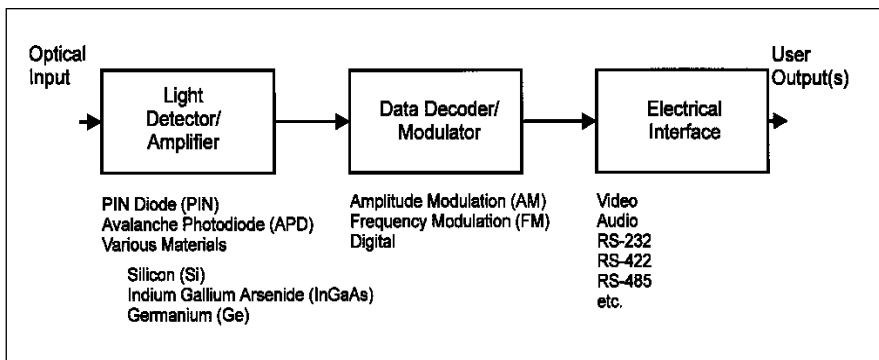

Figure 4. Fiber-optic receiver (courtesy of Force, Inc.).

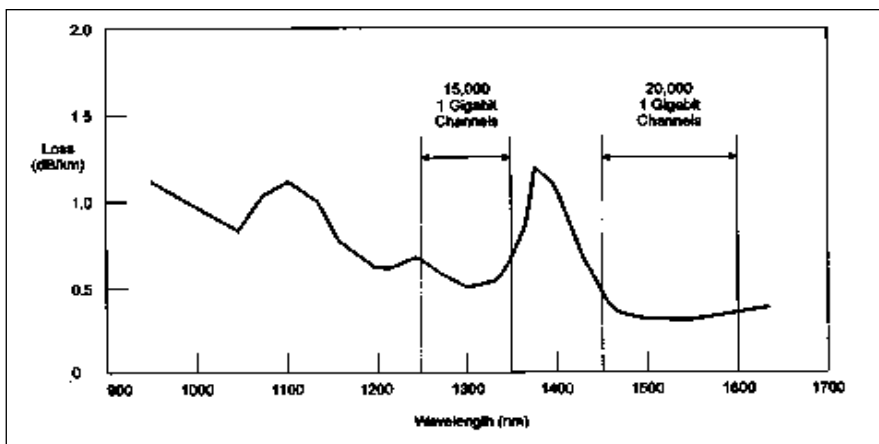

Figure 5. Bandwidth capacity of single-mode fiber.

ing, absorption, and dispersion. Together these combine into an overall heading of attenuation.

Scattering and absorption are caused by nonuniformities and impurities within the fiber-optic cable (the exact nature of these losses will not be covered within this tutorial). Dispersion basically refers to the spreading of the light as it travels down the fiber.

There are several types of dispersion: multimode, chromatic, material, waveguide, and profile. A complete discussion of the properties of all these types of dispersion is beyond the scope of this tutorial, and the reader is encouraged to seek further material that deals with this and related subjects in some depth.

Briefly, multimode dispersion refers to the fact that the different modes can

travel at varying speeds within a multimode fiber. Chromatic dispersion refers to the phenomenon whereby different wavelengths travel at varying rates even within the same mode (chromatic dispersion is the result of material, waveguide, or profile dispersion). Material dispersion refers to the fact that different wavelengths travel at varying speeds through the material. Waveguide dispersion is more important for SM than for MM applications and refers to the fact that light travels at different rates between the core and the cladding. Profile dispersion is a combination of how the refractive indices of the core and cladding affect the group velocity.

Wavelength and Bandwidth

The wavelengths that are mainly used for fiber-optic transmission are 1310 nm and 1550 nm. Prior to this, 850 nm was popular, given the LED and detector technology that was available. This brings up the question, why these particular wavelengths? The answer is relatively simple and rests within experimentation. In Fig. 5 it can be seen that losses (expressed in dB/km) are lower at these particular wavelengths.

Note that the 1550 nm is only used for more specialized applications where long distances are required with no repeaters. While this may sound better, it does have its drawbacks. The basic rule of thumb here is that performance and cost increase with increased wavelength. Therefore, for the time being, 1310 nm is the best overall choice.

A further drawback to the use of the 1550-nm wavelength is the large

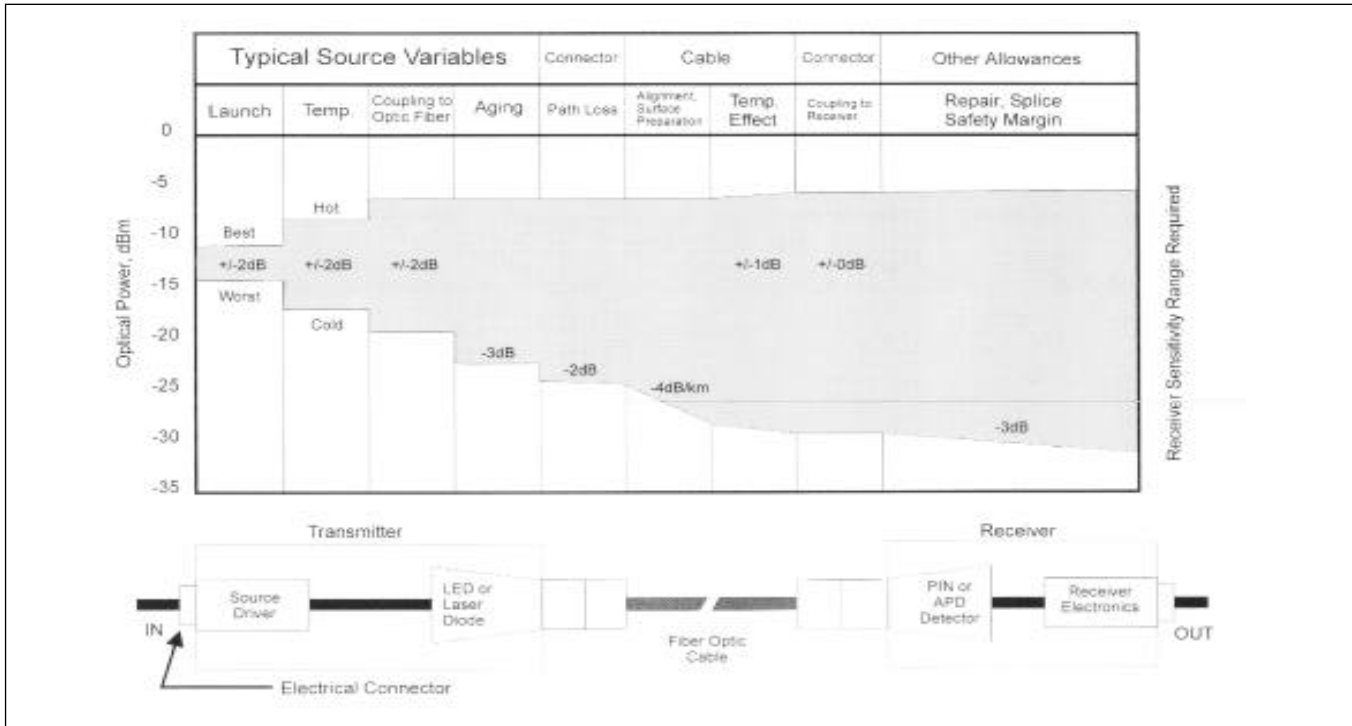

Figure 6. Optical link loss budget (courtesy of Force, Inc.).

increase in the chromatic dispersion when used in conjunction with conventional single-mode fibers. Briefly, the dispersion is almost an order of magnitude larger for 1550 nm versus 1310 nm. There is the potential to overcome this obstacle by using dispersion-shifted fiber; however, there is a fairly large installed base of conventional single-mode fiber already, so this solution is not so easily accomplished. Further investigation will doubtless provide an answer or, at the very least, a workable compromise.

As a last note, this same graph also shows why fiber-optic transmission is gaining such wide popularity. The capacity of a single fiber-optic channel is enormous.

System Design Considerations

As with any transmission system, there are a number of factors which must be taken into consideration during the design process. In the case of a fiber-optic system design, this is collectively referred to as the optical link loss budget (Fig. 6).

Note that each element within the transmission path accounts for a degree of attenuation. The system designer must see that all factors are considered to ensure that there is suffi-

cient power available at the receiver to allow recovery of the original signal.

Conclusion

The last element to be considered is that of multiplexing. Although single-point transmission does have its uses, the benefits of multiple-point transmission combined with multiple channels are obvious. ATM is a readily available example.

There are numerous multiplexing schemes, such as wavelength division multiplexing (WDM), frequency divi-

sion multiplexing (FDM), time division multiplexing (TDM), etc., all of which are interrelated.

Research is ongoing in this area, and the near future may see multiplexed capacities of 4,000 20-GHz channels using FDM techniques.

This tutorial has briefly touched on some of the key issues concerning fiber optics. There are many articles and texts available that go into much greater detail than has been possible here, including a number of articles in recent issues of the *SMPTE Journal*.

THE AUTHOR



Geoff Snell

Geoff Snell is manager, systems engineering, at Leitch Technology International, Inc., Ottawa, Ontario, Canada. In that capacity he is responsible for sales of all Leitch products, R&D product definition, and overseeing all aspects of intellectual property, including patents, trademarks, and contractual documents. After graduating in 1981 from Algonquin College of Applied Arts and Technology in Ottawa with a degree in electronic engineering technology, Snell joined the CBC as a senior maintenance technician. He remained there until 1985, when he took the position of marketing manager at Image Video Ltd. In January 1990 he moved to the Leitch Technology Centre and assumed his current responsibilities.